

## SURFACE MK

- Turn off power before installation.
- Refer to panel light instructions for connections.

**Pack Contents:**

- 1 x Surface mounting box
- 4 x corner brackets
- 4 x screws and wall plugs



### STEP 1

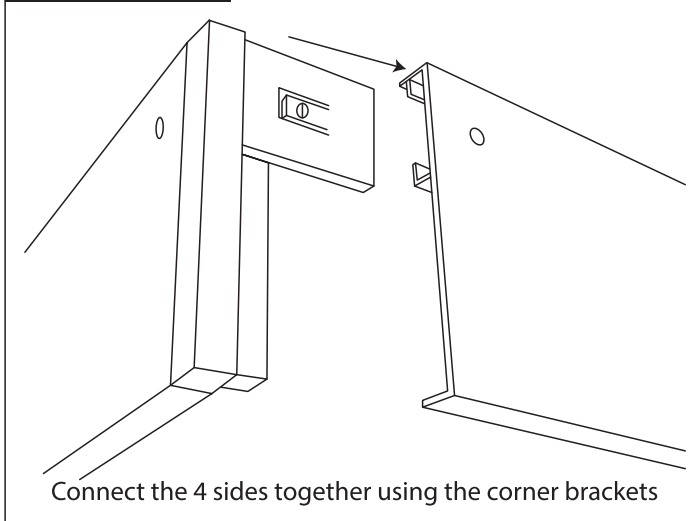

### STEP 2

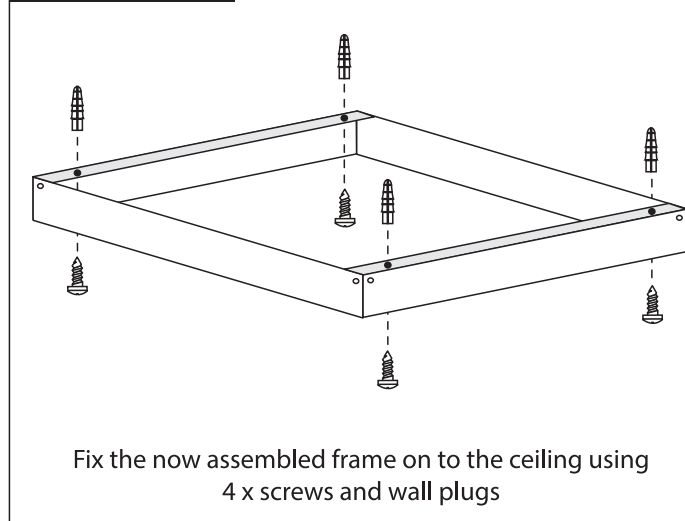

### STEP 3

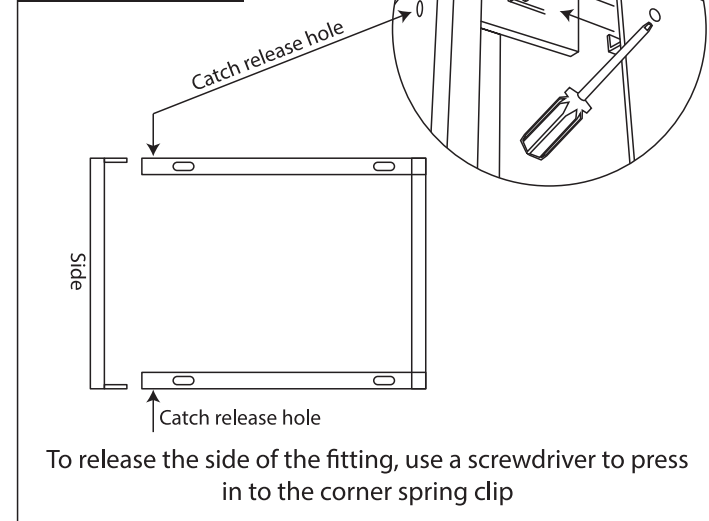

### STEP 4

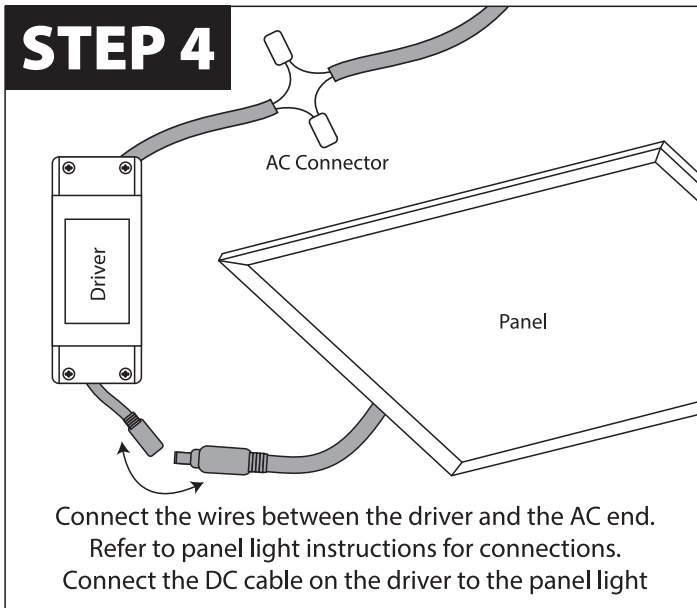

### STEP 5

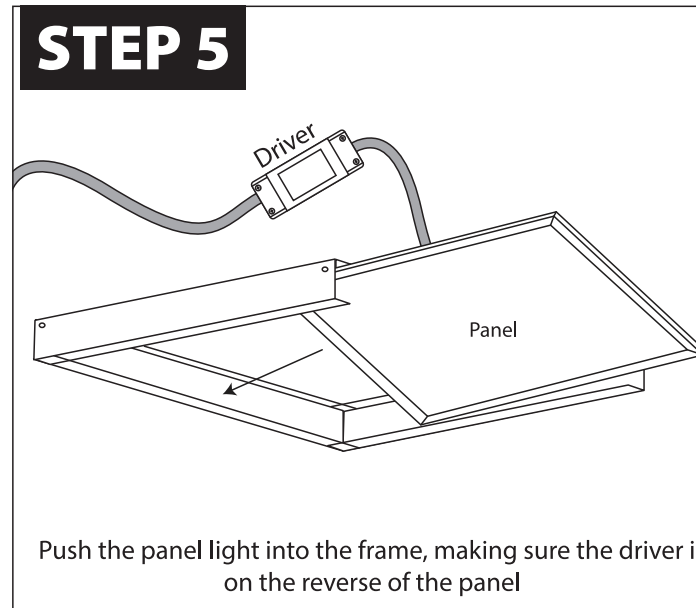

### STEP 6

